



Manufacturer: Multivac
Type: R530
Year Built: 2000

This used Multivac R530 Thermoformer is built in 2000. The machine has a film width of 459mm and there is a dye set on the machine with an exit of 230mm. The format is now divided in a 3.1 format. The machine is equipped with 2 formats. These formats can be used for Rigid film packaging. The format does not have a stamp. The frame of the machine is currently 6375mm long, but we can always adjust this to the dimension you need.

Machine details

- Type under foil unwinding: 76mm Core.
- Type top foil unwinding: 76mm core.
- The machine has 1 QRP cut.
- The machine is equipped with a Cassette Undercut length cutting.
- For the process the residual foil is a Roll-up wheels on this machine.
- This machine has no output belt.

Other features of the machine

- Vacuum option
- Gas flushing
- label option
- Forming Pump

If you wish, you can contact us more photos or information.

MK GILZE



GILZE

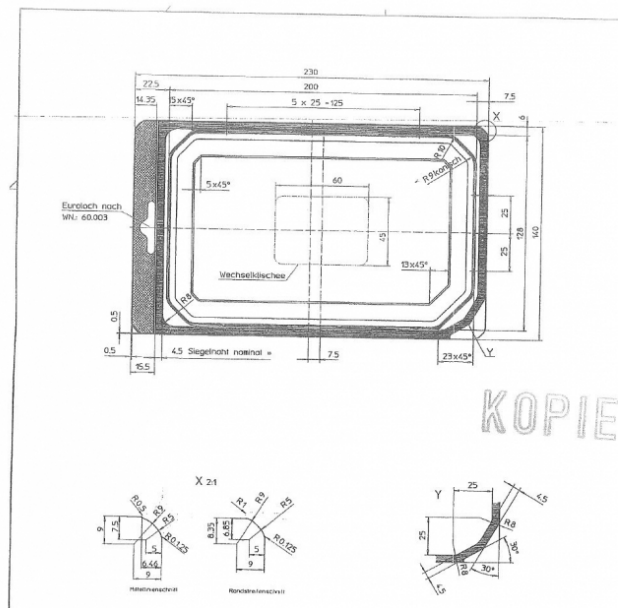
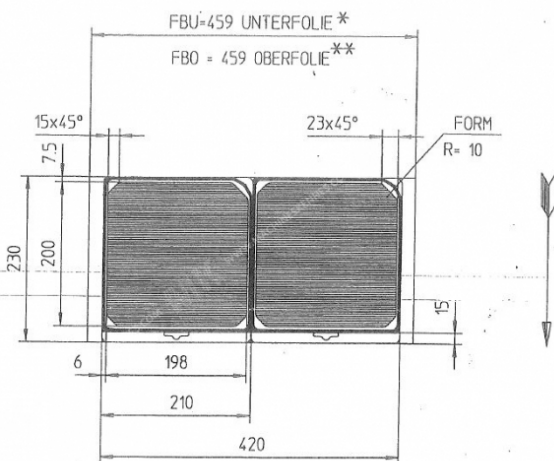
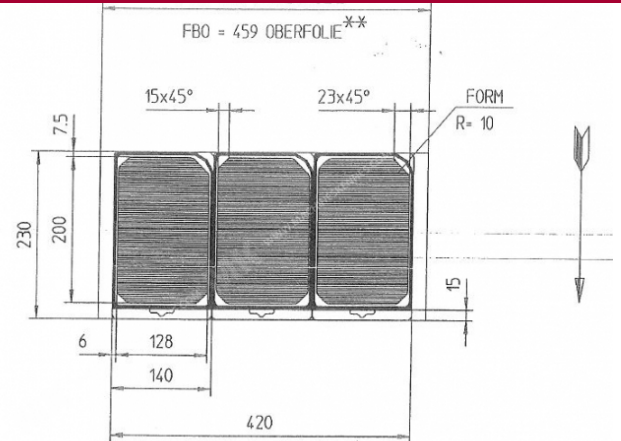

KOPIE

